

IMPORTANT:
THESE INSTRUCTIONS ARE TO
REMAIN WITH THE HOMEOWNER
SAVE THESE INSTRUCTIONS

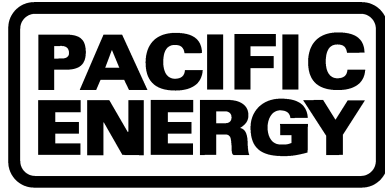

SERIAL #

SAFETY NOTICE

If this stove is not properly installed, a house fire may result. For your safety, follow the installation directions. Consult local building inspector or officials about restrictions and installation inspection requirements in your area.

Super Insert INSTALLATION AND OPERATING INSTRUCTIONS



**MODEL:
SUPER INSERT
DESIGN-E
SPNE**

**TESTED and LISTED
to ULC S628 / UL 1482**
Meets the U.S. Environmental Protection
Agency's July 1990 Particulate Emission
Standards



Contents

Safety	3
Clearances	3
Masonry or Factory Built Fireplace.....	3
Maintenance Checks	4
Dimensions	6
Installation	7
Fireplace Specifications.....	7
Into a Masonry Fireplace.....	7
Full Flue Liner (Required in Canada) Fig #2.....	8
Direct Flue Connection (Only permitted in USA) Fig #4.....	8
Into a Factory Built Fireplace.....	8
Fan Speed Controller Relocation.....	9
Surround Assembly and Installation.....	11
Combustion Air.....	12
Operation	13
Wood Selection.....	13
How to Test Your Wood.....	13
Lighting the Fire.....	13
Normal Operation.....	13
Restarting After Extended or Overnight Burns.....	13
Over Firing.....	13
More Wood, More Heat.....	14
Proper Draft.....	14
Ash Removal.....	14
Disposal of Ashes.....	14
Blower	14
Blower Operation.....	14
Electrical Supply.....	14
Creosote	15
Formation and Need for Removal.....	15
Chimney Fires.....	15
In Case of a Chimney Fire.....	15
Avoiding a Chimney Fire.....	15
Maintenance	16
Baffle Removal.....	16
Replacement Parts	17
Appendix A	18
Understanding & Operating Your Pacific Energy Stove.....	18
Troubleshooting.....	19
Firebrick Installation	20
Label.....	23

Safety

READ ALL INSTRUCTIONS BEFORE INSTALLING AND USING THIS APPLIANCE.

We strongly recommend that smoke detectors be installed. If smoke detectors have been previously installed, you may notice that they are operating more frequently. This may be due to curing of stove paint or fumes caused by accidentally leaving the fire door open. Do not disconnect the detectors. If necessary, relocate them to reduce their sensitivity.

SAFETY NOTICE: If this stove is not properly installed, a house fire may result. For your safety, follow the installation directions. Consult local building or fire officials about restrictions and installation inspection requirements in your area.

Clearances

Masonry or Factory Built Fireplace

The minimum required clearances to surrounding combustible materials when installed into a masonry or factory built fireplace are listed below and in figure #1.

Minimum Clearances to Combustibles (Measured From Insert Body)

Adjacent Sidewall	10in. (254 mm.)
Mantel.....	15 in. (381 mm.)
Top Facing	15 in. (381 mm.)
Side Facing (1.5 in. extension) ...	6.5 in. (165 mm.)

NATIONAL
FIREPLACE
INSTITUTE



CERTIFIED
www.nficertified.org

We recommend that our products be installed and serviced by professionals who are certified in the U.S. by the National Fireplace Institute (NFI) or in Canada by Wood Energy Technical Training (WETT)



Fig. # 1

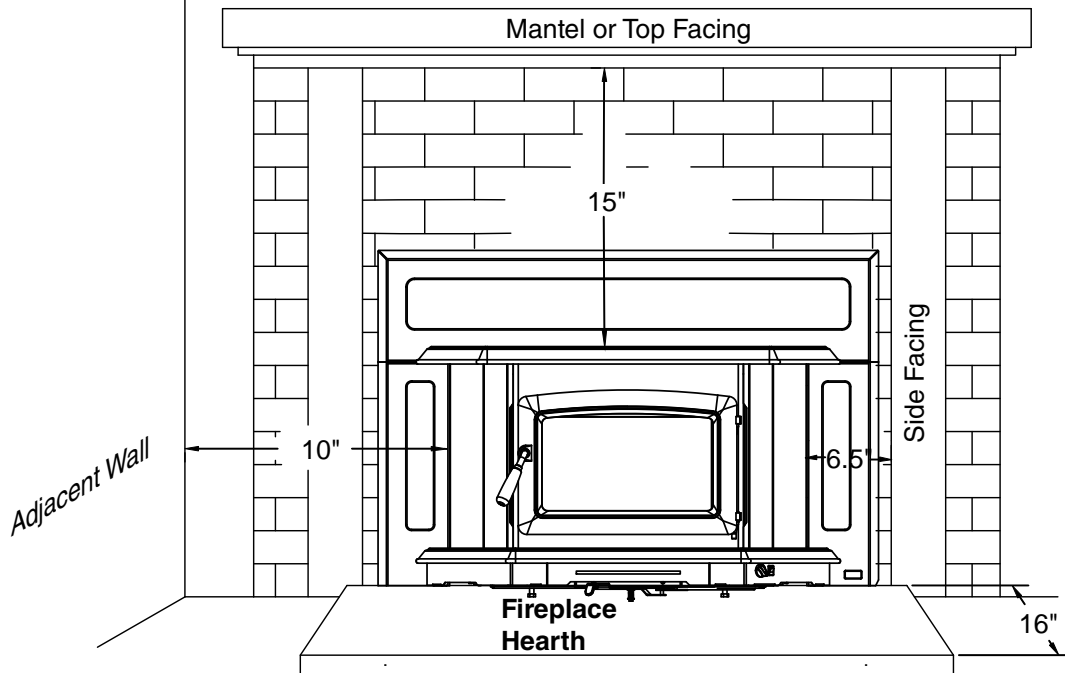

Maintenance Checks

Check the following parts for damage such as cracks, excessive corrosion, burned out sections and excessive warping: (See website for descriptions and more detail)

Weekly:

- Firebrick - Visual, for cracking.
- Door Gasket - sagging, placement, damage.

Monthly

- Brick rail tabs and brick rails.
- Air riser tube in the back of the firebox.
- Back side of airwash chamber.
- Baffle locking pin.
- Boost tube cover.

When Cleaning the Chimney System:

- Top baffle board/blanket.
 - Baffle.
 - Top heat shield and mounting bolt.
 - Baffle Gasket.
 - Brick Rails.
 - Manifold.
- Some warping of the baffle is normal(up to 1/4" or .65cm).
- Replace if the baffle has permanent warping greater than this or has cracking or breakage.
- Please contact your Dealer if you experience any of the damage listed above. Continuing to operate your stove with broken parts may accelerate damage to other parts and may void your warranty

Blowers:

- The blowers should be cleaned out a minimum every six months by using a vacuum on the blower intakes to remove any dust and debris. See "Fan Speed Controller Relocation" section on page 9, steps 1 & 2, for how to remove the panels and access the blowers.

★ Fireplace hearth requirements: (Measured without the insert)

The non-combustible fireplace hearth must extend 16" in front and 8" beyond each side of the existing fireplace opening.

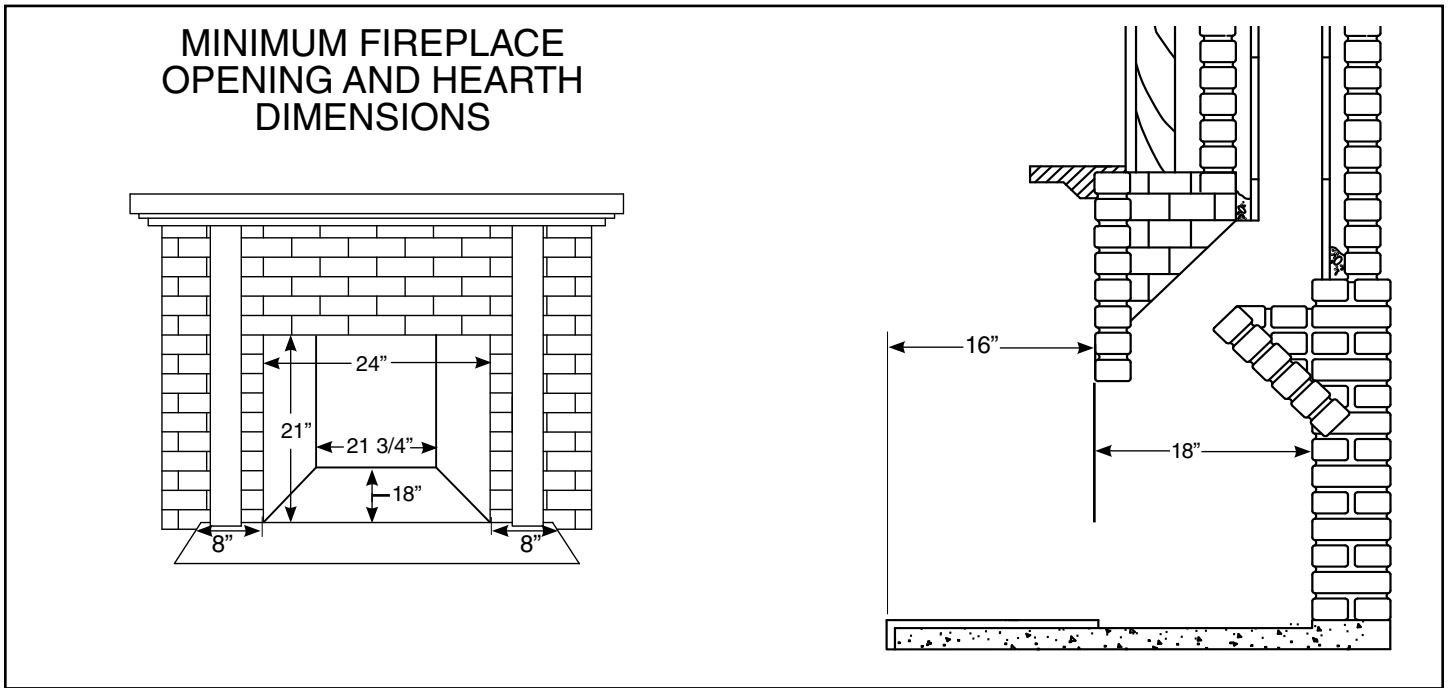

★★ Ember protection:

Combustible floor in front of the fireplace insert must be protected from hot embers by non-combustible material extending 16" (USA) and 18" (CANADA) to the firing side and 8" to other sides of the unit.

Consult CAN/CSA-B365 Installation Code for Solid-Fuel-Burning appliances and equipment in Canada, and N.F.P.A. 211 Standard for chimneys, fireplaces, vents and Solid-Fuel-Burning appliances in USA.

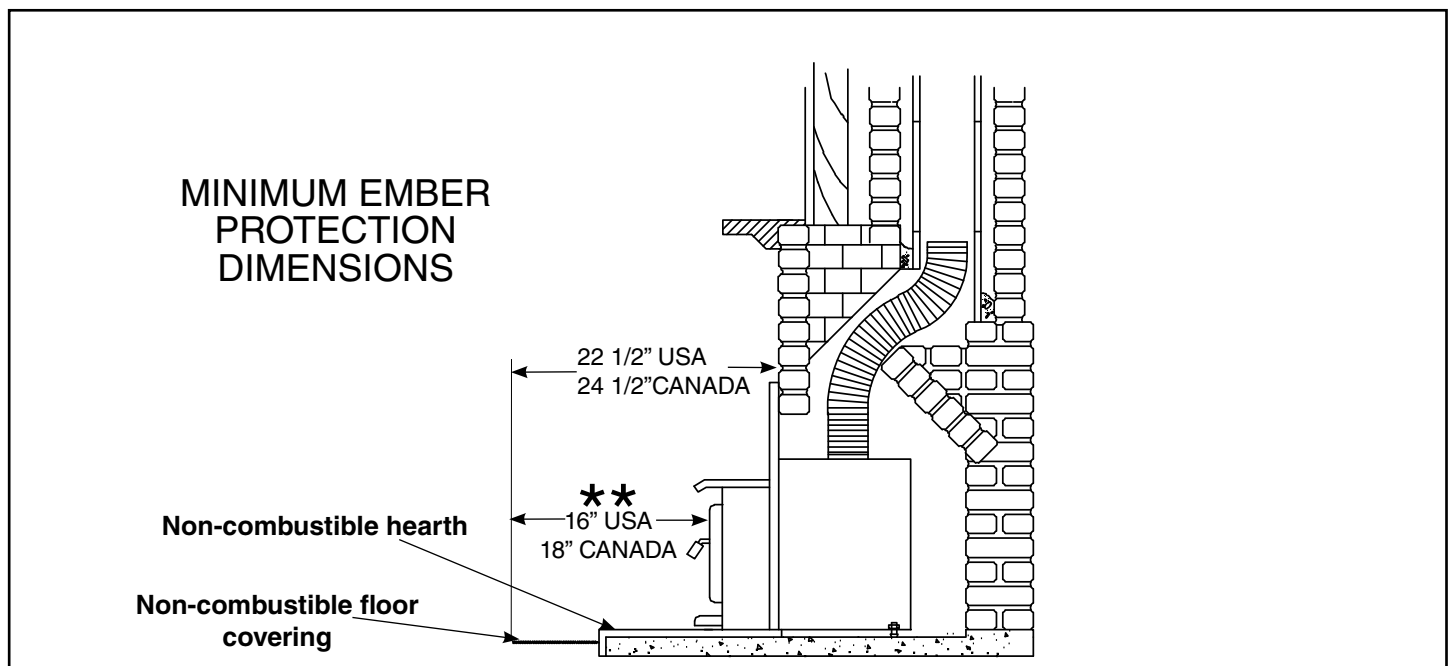

Dimensions

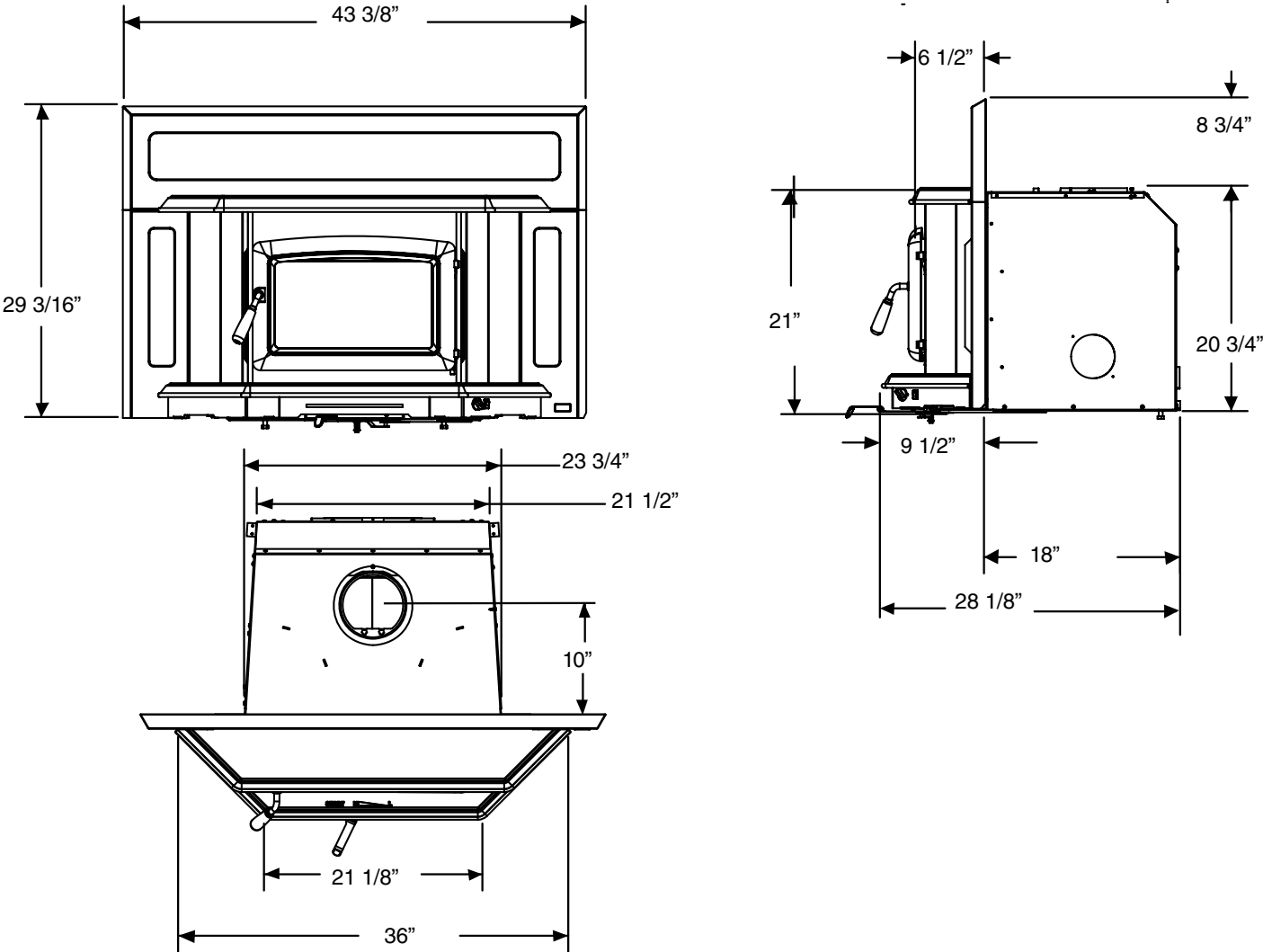

Installation

Your Insert is designed to be installed into a masonry or factory-built, zero-clearance fireplace. The masonry fireplace must be built according to the requirements of the Standard of Chimneys, Fireplaces, Vents and Solid Fuel Burning appliances, N.F.P.A. 211 (Latest Edition) or applicable National, Provincial, State or local codes. The installation shall conform to CAN/CSA-B365, Installation Code for Solid-Fuel-Burning Appliances and Equipment. The factory-built, zero-clearance fireplace and its chimney must be listed per UL 127 or ULC S610 standards.

Warning: Under no circumstances is this heater to be installed in a makeshift or "temporary" manner.

DO NOT CONNECT THIS UNIT TO A CHIMNEY FLUE SERVICING ANOTHER APPLIANCE.

Fireplace Specifications

Your fireplace is required to have the following minimum sizes:

WIDTH (at front)	23 3/4" (602.44 mm)
WIDTH (at rear)	21-3/4" (552.5 mm)
HEIGHT	21" (533.4 mm)
DEPTH	18" (457.2 mm)

Chimney height 15' (minimum)

A metal tag is provided and is to be fastened to the back wall of the fireplace, if the fireplace has been modified to accommodate the insert.

Into a Masonry Fireplace

Inspect your fireplace for cracks, loose mortar or other physical defects. If repairs are required, they should be completed before installing your insert.

The fireplace chimney must be suitable for wood burning use. Check for creosote build up or other obstructions, especially if it has not been in use for some time.

The existing fireplace damper is to be locked open or removed completely.

WARNING: Do not remove bricks or mortar from your existing fireplace.

Exception: Masonry or steel, including the damper plate, may be removed from the smoke shelf and adjacent damper frame if necessary to accommodate a chimney liner, provided that their removal will not weaken the structure of the fireplace and chimney, and will not reduce protection for combustible materials to less than that required by the National Building Code.

The Insert must be installed in accordance with local and or national building codes. The two methods of flue connection that are acceptable in most areas are:

Full Flue Liner: (Fig.2) where a stainless steel rigid or flexible liner extends from the Insert flue collar to the top of the chimney. Positive Flue Connection: where a throat blocker plate and a short connector pipe is used.

Note: A clean-out door may be required under local codes, when a positive flue connection is used. Consult local codes.

Fig. # 2

Full Flue Liner (Required in Canada)

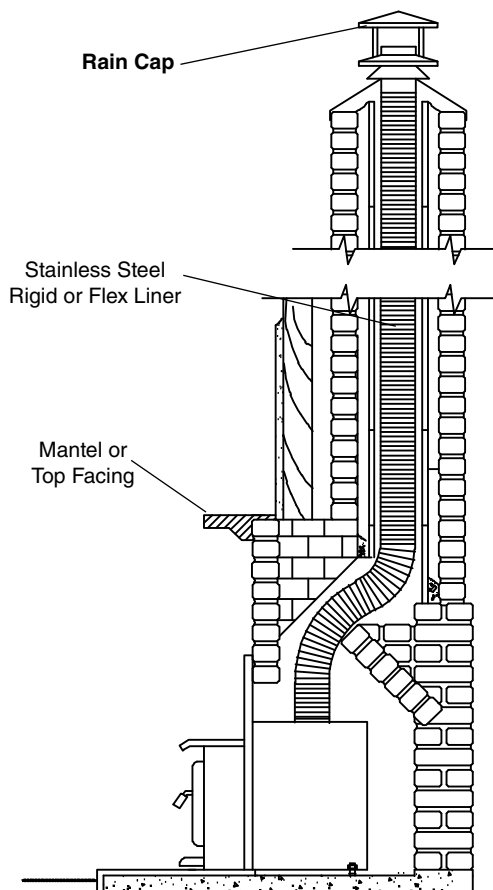

Pacific Energy highly recommends the use of a full liner as the safest installation and providing optimum performance. When connected to a full liner, the Insert is able to draft correctly and will prevent problems such as difficult start-ups and smoking out the door.

For difficult installations, this insert is approved for use with a SPND.3OFFSETA - 3" flue offset box. Only this offset box is approved for use with this insert. The use of any other offset box may cause a hazard and/ or void any warranty.

Full Flue Liner (Required in Canada) Fig #2

This fireplace insert must be installed with a continuous liner of 6" diameter extending from the fireplace insert to the top of the chimney. The chimney liner must conform to the class 3 requirements of CAN/ULC-S635, Standard for Lining systems for Existing Masonry or Factory-Built Chimneys or Vents, or CAN/ULC-S640, Standard for lining systems for New Masonry Chimneys.

- 1) Measure the chimney height from the top of the existing flue to the floor of the hearth. This will allow extra length of liner for flashing and rain cap.
- 2) Feed the stainless steel liner from the top of the chimney, through the damper area and into the fireplace cavity.
- 3) Attach a stove connector to the bottom of the liner, as per the instructions provided with the chimney liner.
- 4) Push the Insert into position inside the fireplace and attach the connector to the stove collar and secure with screws. Use the rear adjusting legs to level the Insert.

Note: For better access, the top of the casing may be removed (Fig. #3). If it is necessary to get access to the connector pipe through the flue outlet of the Insert, the baffle can be removed (see Baffle Removal section).

- 5) Measure, trim and shape a top flashing to fit the existing chimney flue. Plan for a 1" to 1-1/2" overlap on each side. Place flashing over top of the liner and seat firmly against the tile.
- 6) Screw flashing collar to liner. Caulk gap around flashing with RTV silicone.
- 7) Attach a rain cap to the end of the liner. A storm collar should be used.

Consult your local Dealer about relining your fireplace chimney.

Direct Flue Connection (Only permitted in USA) Fig #4

- 1) Measure from the first chimney flue liner to the top of the Insert. Allow extra length of liner to insert into flue tile.
- 2) Feed the stainless steel liner through the damper area and into the first chimney flue tile. Seal around pipe.

Note: A clean-out door may be required under local codes, when a direct flue connection is used. Consult local codes.

- 3) Push the Insert into position inside the fireplace and attach the connector pipe to the stove collar. Use the rear adjusting legs to level the Insert.

Note: For better access, the top of the casing may be removed (Fig. #3). If it is necessary to get access to the connector pipe through the flue outlet of the Insert, the baffle can be removed (see Baffle Removal section).

Into a Factory Built Fireplace

Your Pacific Insert may be installed into a factory built fireplace with the following requirements:

- 1) Inspect your fireplace for damage or other physical defects. The fireplace must be in good working condition. If in doubt about its condition, seek professional advice. Check for creosote build up or other obstructions inside the chimney, especially if it has not been in use for some time. Before installing, clean your chimney system thoroughly.
- 2) A full stainless steel rigid or flexible flue liner meeting type HT requirements (2100°F) per UL1777(U.S.) or ULC S635 (Canada) must be used for both safety and performance. The liner must be securely attached to the insert flue collar and the chimney top.

- 3) The surround must be sealed to the fireplace front or the damper area around the chimney liner must be sealed to prevent room air entering the chimney cavity of the fireplace.
- 4) The air flow within and around the fireplace must not be altered by the installation of the Insert (i.e. no blockage of louvers or cooling air inlet or outlet ports). This includes the circulating air chambers in a steel fireplace or metal heat circulator.
- 5) Alteration of the fireplace in any manner is not permitted with the following exceptions:
 - a: external trim pieces which do not affect the operation of the fireplace may be removed and stored on or within the fireplace for re-assembly if the Insert is removed.
 - b: the chimney damper may be removed to install the liner.

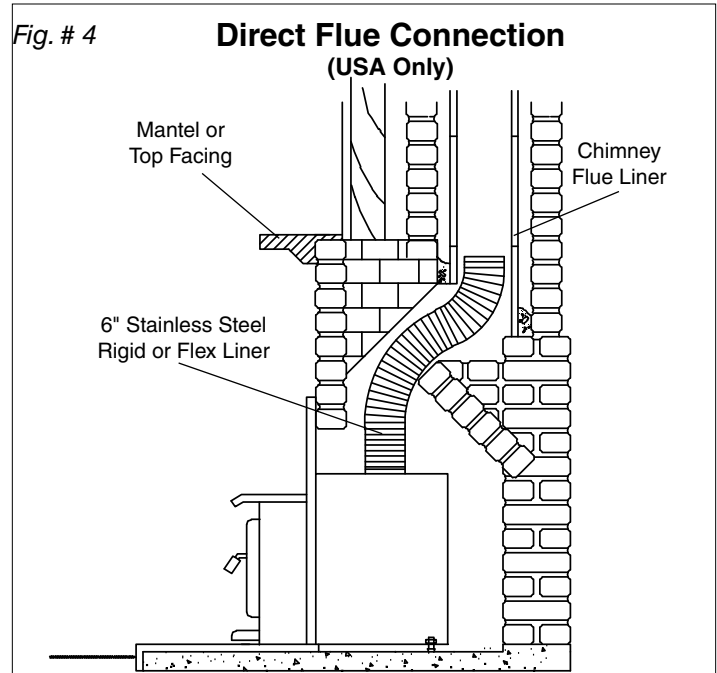
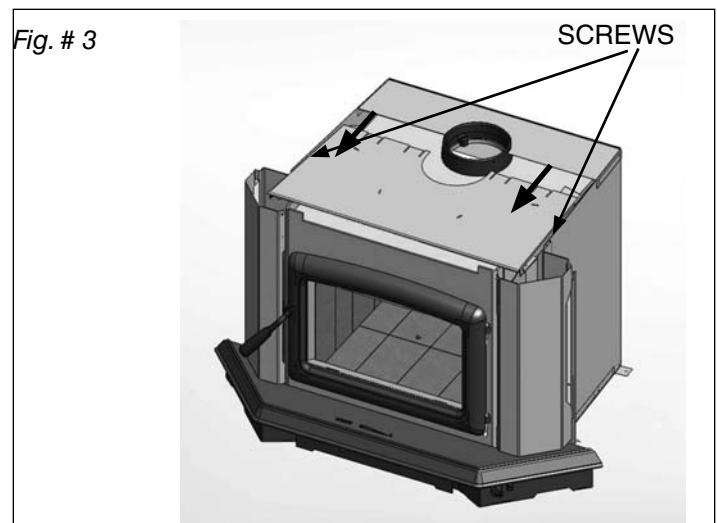

Fan Speed Controller Relocation

The fan speed controller is factory installed under the ash lip on the right hand side. If required, it can be relocated to the left side by following the instructions below. To make this as easy as possible, it is suggested that this be done prior to fitting the surround and installation into the fireplace:

- 1) Lift up on each panel and remove. Set aside to prevent damage.

Fig. # 5



- 2) Disconnect the wires from the fans (LHS & RHS) and thermal snap switch. Take note of where the wires are routed and secured. They must be positioned correctly to avoid damage.

Fig. # 6



- 3) Loosen the two bolts that secure the ash lip to the firebox, carefully lift up the ash lip and remove from the firebox and unscrew the wire support tabs

Fig. # 7

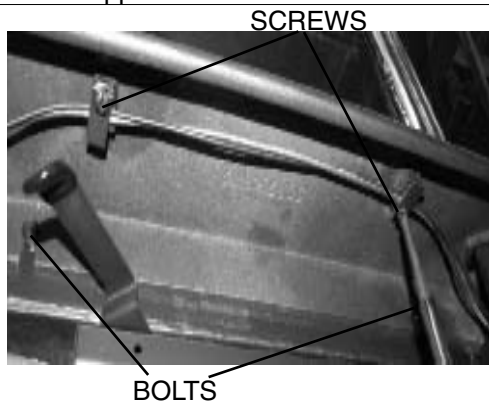

- 4) Remove the two screws securing the speed controls assembly to the ash lip. The cover plate on the opposite side can also be removed at this time

Fig. # 8

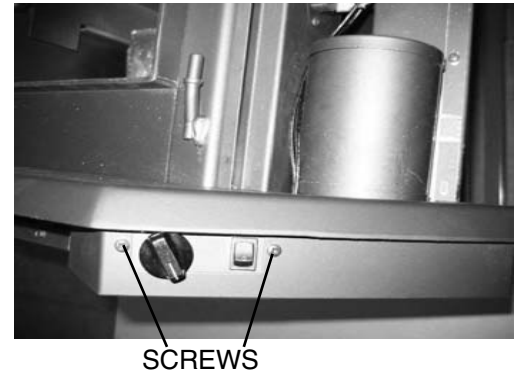

- 5) Remove the control assembly from the right hand side of the ashlip. Flip it over and reattach on the left hand side of the ashlip. Use the upper screw holes for best alignment.

Fig. # 9



Fig. # 10



6) Route cable from speed control to fan and reattach wire support tabs on the underside of the ash lip. Note wire positions. (Fig.11 & Fig.12)

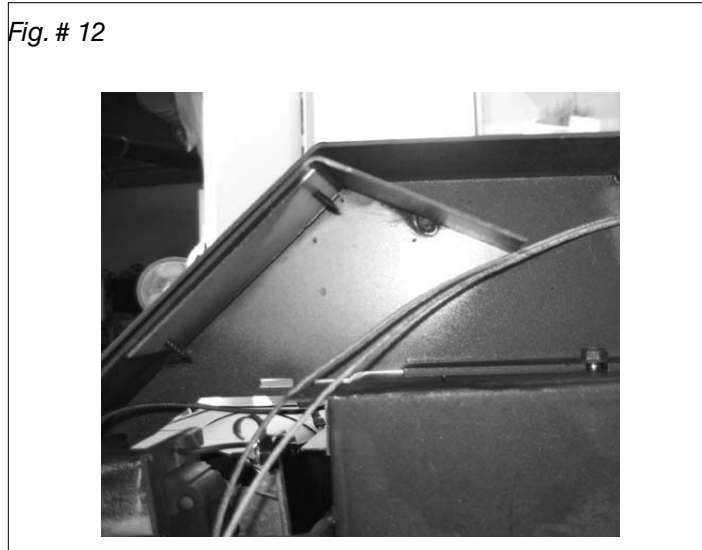
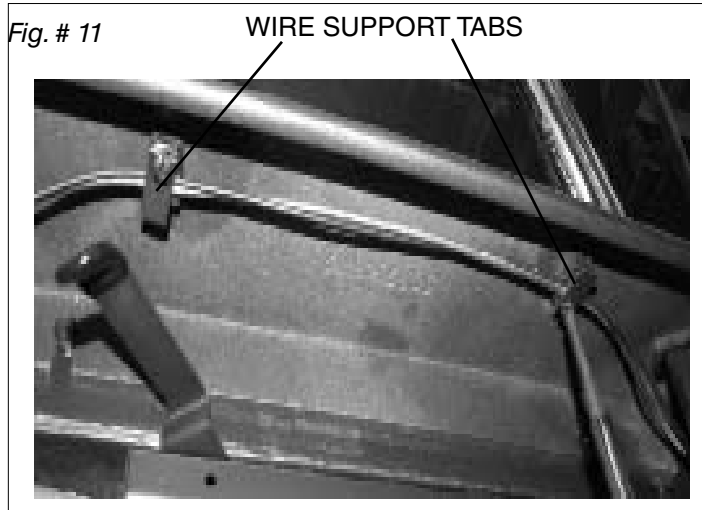

7) Remove Thermal switch from right hand fan mounting bracket and relocate to left hand fan mounting bracket. Fig #13&14

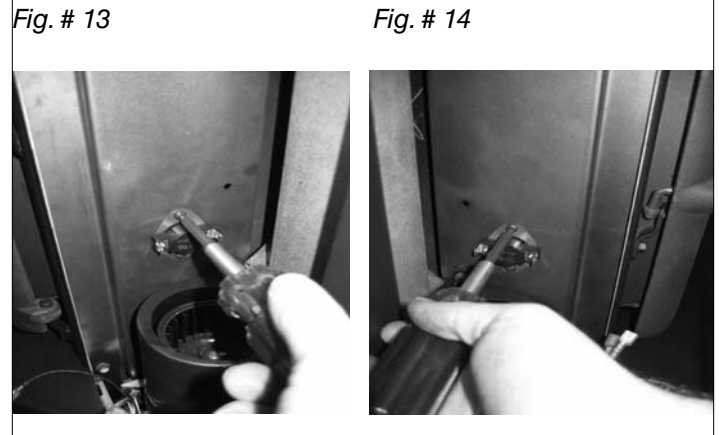

8) Reconnect the wires to the fans (Fig.15) and thermal snap switch (Fig.16), refit ash lip, sides and top. Ensure that the power cable is correctly routed through the surround and it is not touching the firebox side. Wire placement is important to prevent damage to wires.



Surround Assembly and Installation

- 1) Lay part A, B and C face down on a flat, non-marring surface. Fasten together with 1/4" x 1/2" bolts and nuts provided through holes at points "D" (Fig. #17).
- 2) Lift the surround assembly to the upright position and make sure the front face is flat and even at the joints.
- 3) Remove the two front panels as described on page 9 and then remove the decorative top by loosening the two wing bolts underneath and sliding it out of the brackets. (Fig. #18).
- 4) Slide the assembled surround from the top down and engage in slots on surround brackets. (Fig. #19 & 20).
- 5) Push the entire appliance back until the surround assembly is in contact with the fireplace structure.
- 6) Position the decorative bay top onto the firebox top. Align and refasten the wing screws.

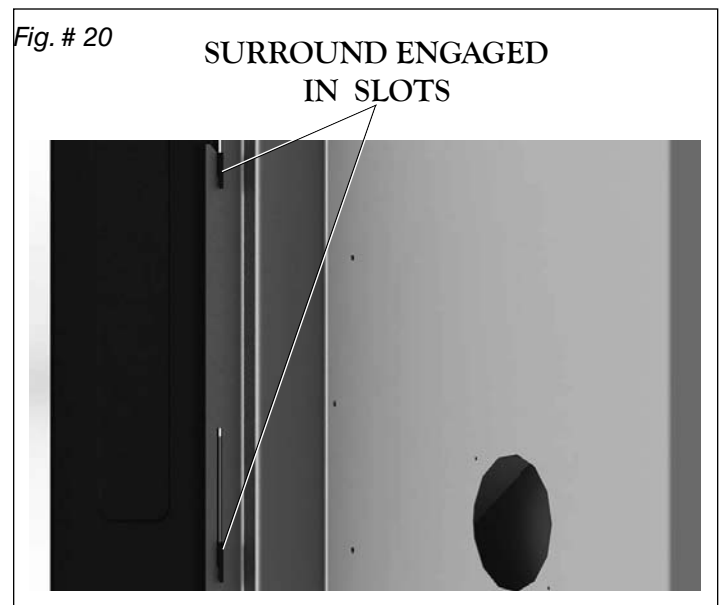
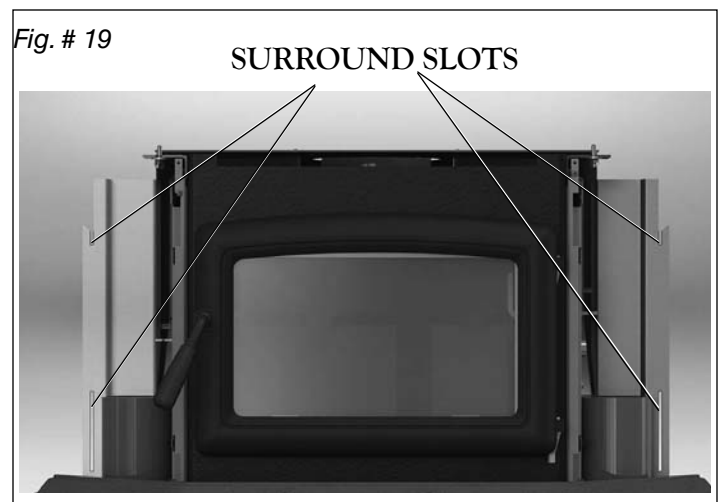
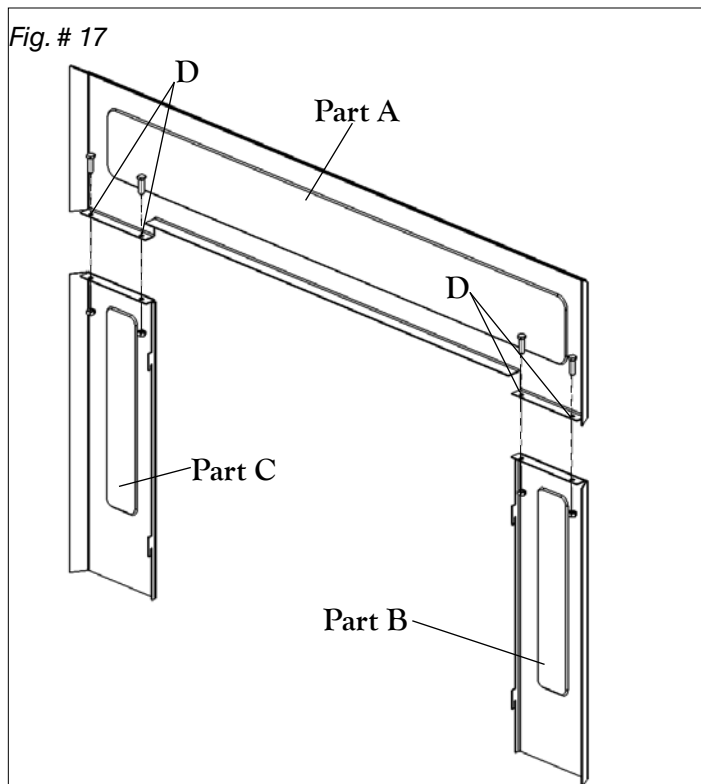

- 7) Replace the front panels.

Combustion Air

Consult local building codes regarding combustion air supply. Intake or combustion air can be supplied to the Insert in one of two ways:

- 1) Outside air (O/A) supply: Remove cover from ash clean out in existing fireplace. Place a rodent screen in place of the cover. Install the Insert as described in the installation section, making sure not to cover the opening of the air inlet. When installation is complete, seal surround to fireplace and anywhere else air may enter. This will ensure combustion air is drawn from outside the house and into the 9" x 2" intake at the lower rear of the appliance.
- 2) Room air supply: Install the Insert as described in the installation section. When the installation is complete, do not seal surround to fireplace. This will allow enough combustion air to enter the fireplace cavity and the Insert.

Removal: The O/A cover should be removed prior to installation. For better access, tip the Insert onto its back.

1. Using a 5/16" wrench, remove the screw securing the O/A cover to the firebox (Fig. #21 & 22).

Fig. # 22



O/A Cover

This unit is not designed to be operated with the firing door open. In addition to the obvious hazard of sparks landing on combustibles, an open fire door will cause the heater to draw air from the living space and possibly cause suffocation. The living space around the heater must be well ventilated with good air circulation. Anything that may cause a negative pressure can cause gases or fumes to be pulled into the living area.

Fig. # 21

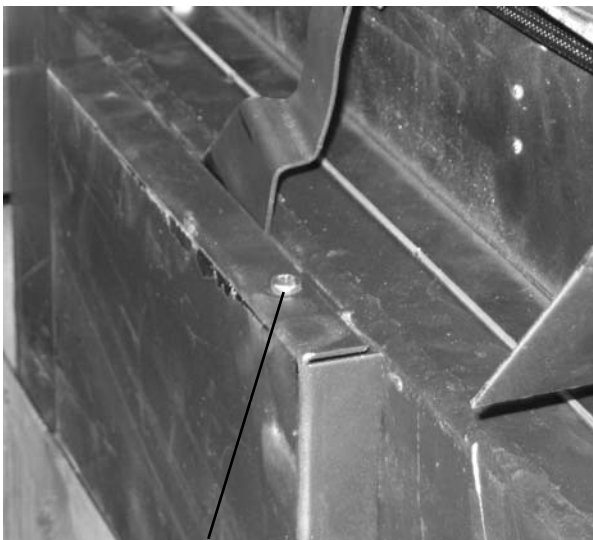

O/A Cover Screw

Operation

Wood Selection

This heater is designed to burn natural wood only. Higher efficiency and lower emissions generally result when burning air-dried seasoned hardwoods, as compared to softwoods or too green or freshly cut hardwoods.

Wood should be properly air dried (seasoned) for six months or more. Wet or undried wood will cause the fire to smoulder and produce large amounts of creosote. Wet wood also produces very little heat and tends to go out often.

DO NOT BURN:

- | | |
|--------------------|--------------------|
| -*Salt water wood | -Coal/charcoal |
| -Treated wood | -*Garbage/Plastics |
| -Wet or green wood | -Solvents |

* These materials contain chlorides which will rapidly destroy metal surfaces and void warranty.

Do not burn anything but wood. Other fuel, e.g. charcoal, can produce large amounts of carbon monoxide, a tasteless, odourless gas that can kill. Under no circumstances should you attempt to barbecue in this heater.

How to Test Your Wood

Add a large piece of wood to the stove when it has a good, large bed of coals. It is dry if it is burning on more than one side within one minute. It is damp if it turns black and lights within three minutes. If it sizzles, hisses and blackens without igniting in five minutes it is soaked and should not be burnt.

WARNING: Do not use grates or andirons to elevate the fuel. Burn directly on the firebricks. Replace broken or missing bricks. Failure to do so may create a hazardous condition.

Your Pacific Energy heater is designed for maximum overall efficiency at a moderate firing rate. Overfiring is hazardous and a waste of fuel. Too slow a burn contributes to creosote buildup and lowers combustion efficiency.

Lighting the Fire

WARNING: Never use gasoline, gasoline-type lantern fuel, kerosene, charcoal lighter fluid, or similar liquids to start or 'freshen up' a fire in this heater. Keep all such liquids well away from the heater while in use.

- 1) Adjust air control to "H" (Start) position (pushed to the far left) and open door.
- 2) Place crumpled newspaper in the centre of the heater and criss-cross with several pieces of dry kindling. Add a few small pieces of dry wood on top.
- 3) Ignite the paper and close the door.
- 4) After the fire has established itself, open the door and add a few small logs. Close door.
- 5) Begin normal operation after a good coal base exists and wood has charred.

Normal Operation

- 1) Set air control to desired setting. If smoke pours down across the glass (waterfall effect), this indicates you have shut the control down too soon or you are using too low a setting. As every home's heating needs vary (i.e. insulation, windows, climate, etc.), the proper setting can only be found by trial and error and should be noted for future burns.
- 2) To refuel, adjust air control to "H" (Start) position (pushed to the far left) and give the fire time to brighten. Turn the blowers "OFF". Open door slowly, this will prevent backpuffing.
- 3) Use wood of different shape, diameter and length (up to 19"). Load your wood endwise and try to place the logs so that air can flow between them. Always use dry wood.
- 4) Do not load fuel to a height or in such a manner that would be hazardous when opening the door.
- 5) For extended or overnight burns, unsplit logs are preferred. Remember to char the wood completely on "H" (high) setting before adjusting air control for overnight burn.

WARNING: Always keep loading door closed when burning. If the door is left partly open, gas and flames may be drawn out of the fireplace stove opening creating risks from fire and/ or smoke. This heater is not designed for open door burning, unless a manufacturer supplied screen is used.

Restarting After Extended or Overnight Burns

- 1) Open door and rake hot embers towards the front of the heater. Add a couple of dry, split logs on top of embers, close door.
- 2) Adjust air control to "H" (Start) position (pushed to the far left) and in just a few minutes, logs should begin burning.
- 3) After wood has charred, reset air control to desired setting.
- 4) When burning at a slow rate for extended periods, occasionally maintain a strong fire under supervision for a couple of hours to relieve firebox and chimney deposits as well as any of the deposits on the glass.

WARNING: This method is not a substitute for regular chimney inspections and cleaning.

- 5) To achieve maximum firing rate, set control to "H" (high) position (pushed to the far left). Do not use this setting other than for starting or preheating fresh fuel loads.

DO NOT OVERFIRE THIS HEATER: Attempts to achieve heat output rates that exceed heater design specifications can result in permanent damage to the heater and chimney.

WARNING: No alteration or modification of the combustion air control assembly is permitted. Any tampering will void warranty and could be very hazardous.

Over Firing

Over firing can be caused by operating the unit with the door open, damage to door gaskets allowing excess air to enter the firebox, the use of kiln dried lumber, mill ends or paper waste and prolonged or continual use on a high burn setting.

More Wood, More Heat

Seasoned wood has approximately 7500 BTU's per pound. If you put 10 pounds of wood in your stove for an eight hour burn the wood will be producing 9375 BTU's per hour. (7500 BTU x 10 lbs / 8 hrs. = 9375 BTU's per hr.). If you put 20 lbs of wood in your stove for an eight hour burn you will get 18,750 BTU's per hr. (7500 BTU x 20 lbs / 8 hrs. = 18,750 BTU's per hr.). This is only an example and is based on 100% efficiency. In reality, your stove should perform in the 82% efficiency range.

Experience will give you the right settings for proper combustion and efficient burning. Remember, the air inlet setting is affected by variables such as type of wood, outside temperature, chimney size and weather conditions. With practice, you will become proficient in operating your heater and will obtain the performance for which it was designed.

Proper Draft

- 1) Draft is the force which moves air from the appliance up through the chimney. The amount of draft in your chimney depends on the length of the chimney, local geography, nearby obstructions and other factors.
- 2) Too much draft may cause excessive temperatures in the appliance. An uncontrollable burn or a glowing red stove part or chimney indicates excessive draft.
- 3) Inadequate draft may cause backpuffing into the room and plugging of the chimney. Smoke leaking into the room through appliance and chimney connector joints indicates inadequate draft.

Ash Removal

Whenever ashes get 3 to 4 inches deep in your firebox, and when fire has burned down and cooled, remove excess ashes. Leave an ash bed approximately 1 inch deep on the firebox bottom to help maintain a hot charcoal bed.

Disposal of Ashes

Ashes should be placed in a metal container with a tight fitting lid. The closed container of ashes should be placed on a non-combustible floor or on the ground, well away from all combustible materials, pending final disposal. If the ashes are disposed of by burial in soil or otherwise locally dispersed, they should be retained in the closed container until all cinders have thoroughly cooled. Other waste should not be placed in this container!

Blower

The Super Insert comes equipped with twin variable speed circulating air blowers. The blower system is thermostatically controlled for automatic operation, as well manually with a convenient bypass switch.

Blower Operation

Automatic: To operate the blowers automatically, push the rocker switch to the "OFF" or "-" position and set the fan speed control to a desired setting.

This will allow the blowers to turn on automatically once the Insert has come up to operating temperature. It will also shut the blower off after the fire has gone out and the appliance has cooled to below a useful heat output range.

Manual: To manually operate the blowers, push the rocker switch to the "ON" or "O" position and set the fan speed control to a desired setting. This will bypass the temperature switch and allow full control of the blower.

Suggested settings:

- Combustion air control setting of "L" (low) position (pushed to the far right), operate blower speed control on "Low".
- Combustion air control set at anything above "L" (low), operate blower speed control at desired setting.

Electrical Supply

Circulating air blower electrical rating; 115V, 60 Hz, 1.1 A. For your protection against shock hazard, use only a properly grounded outlet that will accept a three-pronged plug. Do not cut or remove the grounding prong.

Consult local codes or, in the absence of local codes, with the current CSA C22.1 Canadian Electrical Code and in the USA with the National Electrical Code, ANSI/NFPA 70 (latest edition).

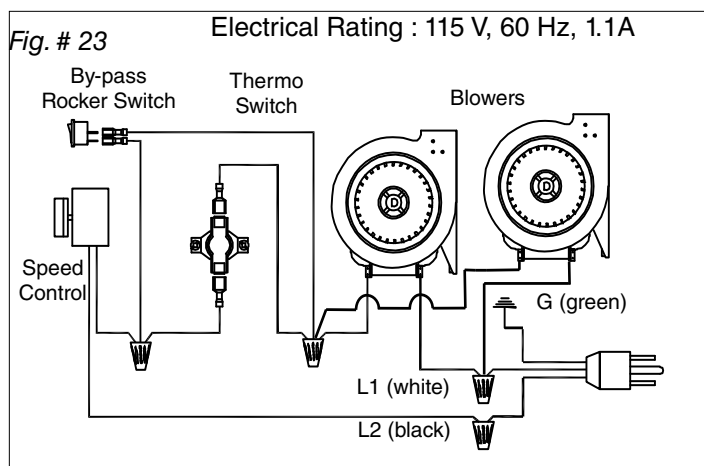

Creosote

Formation and Need for Removal

When wood is burned slowly, it produces tar and other organic vapours, which combine with expelled moisture to form creosote. The creosote vapours condense in the relatively cool chimney flue of a slow burning fire. As a result, creosote residue accumulates on the flue lining. When ignited, this creosote makes an extremely hot fire. The chimney connector and chimney should be inspected at least once every two months during the heating season to determine if a creosote buildup has occurred. If creosote has accumulated, it should be removed to reduce the risk of a chimney fire.

1. Highest smoke densities occur when a large amount of wood is added to a bed of hot coals and the air inlet is closed. The heated wood generates smoke, but without ample air, the smoke cannot burn. Smoke-free, clean burning requires small fuel loads, two or three logs at a time or 1/4 to 1/2 of a fuel load and leaving the air inlet relatively wide open, especially during the first 10 to 30 minutes after each loading, when most of the smoke generating reactions are occurring. After 30 minutes or so, the air inlet can be turned down substantially without excessive smoke generation. Wood coals create very little creosote-producing smoke.
2. The cooler the surface over which wood smoke is passing, the more creosote will be condensed. Wet or green wood contributes significantly to creosote formation as the excess moisture that is boiled off cools the fire, making it difficult for the tars and gasses to ignite, thus creating dense smoke and poor combustion. This moisture-laden smoke cools the chimney, compounding the problem by offering the smoke the ideal place to condense.

In summary, a certain amount of creosote is inevitable and must be lived with. Regular inspection and cleaning is the solution. The use of dry, seasoned wood and ample combustion air will help to minimize the buildup.

Chimney Fires

The result of excessive creosote buildup is a chimney fire. Chimney fires are dangerous. Chimney inside temperatures can exceed 2000 degrees F. This causes much higher than normal temperatures in the chimney and on its exterior surfaces thus ignition of nearby or touching combustible material is more likely during a chimney fire. Proper clearances are critical if such a fire should occur.

Chimney fires are easy to detect; they usually involve one or more of the following:

- Flames and sparks shooting out of the top of the chimney
- A roaring sound
- Vibration of the chimney

In Case of a Chimney Fire

1. Prepare to evacuate to ensure everyone's safety. Have a well understood plan of action for evacuation. Have a place outside where everyone is to meet.
2. Close air inlets on stove.

3. Call local fire department. Have a fire extinguisher handy. Contact your local fire authority for further information on how to handle a chimney fire. It is most important that you have a clearly understood plan on how to handle a chimney fire.
4. After the chimney fire is out, the chimney must be cleaned and checked for stress and cracking before starting another fire. Also check combustibles around chimney and the roof.

Avoiding a Chimney Fire

There are two ways to avoid chimney fires:

1. Do not let creosote build up to a point where a chimney fire is possible.
2. Do not have fires in the heater that may ignite chimney fires. These are hot fires, such as when burning household trash, cardboard, Christmas tree limbs, or even ordinary fuel wood; (eg. with a full load on a hot bed of coals and with the air inlet wide open).

Maintenance

1. Burn wood only, dry and well seasoned. The denser or heavier the wood when dry, the greater its heat value. This is why hardwoods are generally preferred. Green or wet wood will cause a rapid buildup of creosote. If you feel it is necessary to burn wet or unseasoned wood, do so only with the air inlet set open enough to maintain a good strong fire and fairly high chimney temperatures. Do not attempt to burn overnight using green or wet wood. Wet wood can cause up to 25% drop in heater output, as well as contributing significantly to creosote buildup.

WARNING: Never use firestarter chemicals or any other volatile liquid to start a fire. Do not burn garbage, or flammable fluids such as gasoline, naphtha, or engine oil. We strongly recommend that smoke detectors be installed.

2. Remove ashes frequently. Embers can roll out the door and create a fire hazard. Maintain a 1" minimum ash base.
3. If glass becomes darkened through slow burning or poor wood, it can readily be cleaned with any fireplace glass cleaner when stove is cold. Never scrape with an object that might scratch the glass. The type and amount of deposit on the glass is a good indication of flue pipe and chimney buildup. A light brown, dusty deposit that is easily wiped off usually indicates good combustion and dry, well-seasoned wood and, therefore, relatively clean pipes and chimney. On the other hand, a black, greasy deposit that is difficult to remove is a result of wet and green wood and too slow a burning rate. This heavy deposit is building up at least as quickly in the chimney.

WARNING: Only use materials supplied by the manufacturer when doing maintenance or replacements.

4. DOOR GASKET - The gasket used by Pacific Energy requires only light pressure to seal. This will prolong seal life. It is important that the door seal be maintained in good condition. Periodically inspect seals and replace if necessary. Use 7/8" rope gasket, DR31.WDGKIT, obtainable from your nearest Pacific Energy Dealer.
5. DOOR GLASS - Do not slam loading door or otherwise impact glass. When closing door, make sure that no logs protrude to contact the glass. If the glass gets cracked or broken, it must be replaced before using the stove. Replacement glass can be obtained from your Dealer. The size required is 8-13/16 x 15-1/4 x 5 mm. Ceramic glass must be used. Do not substitute with any other type.

To remove broken glass, undo the four retaining screws and remove the frame noting position for re-assembly. Remove all particles of glass. Be careful, as they are very sharp. Install new glass complete with gasket. Replace frame and screws.

WARNING: Do not overtighten, tighten screws very carefully.

- Do not clean glass when hot
- Do not use abrasive cleaners on glass

6. The area where boost combustion air enters the firebox must be kept clear of excessive ash buildup which will block air flow. This area is at the front of the firebox.

7. Do not store wood within heater installation clearances, or within the space required for fuel loading and ash removal. Keep the area around the heater clean and free of all combustibles, furniture, newspapers, etc.
8. If a plated door requires cleaning, use mild soap and water only. Use of abrasive cleaners will void warranty.
9. Establish a routine for the fuel, wood burning and firing technique. Check daily for creosote buildup until experience shows how often you need to clean to be safe.
10. Be aware that the hotter the fire, the less creosote is deposited. Weekly cleaning may be necessary in mild weather, even though monthly cleaning is usually enough in the coldest months when burning rates are higher.
11. Instruct all members of your family on the safe operation of the heater. Ensure they have enough knowledge of the entire system if they are expected to operate it. Stress the section on chimney fires and the importance of following the steps outlined in "In Case of Chimney Fire"

Baffle Removal

The Insert and pipe should be removed from the fireplace to clean and inspect. Only if this is not possible should you remove baffle assembly.

DO NOT OPERATE WITH BAFFLE ASSEMBLY OR INSULATION REMOVED.

Baffle Assembly Removal

Remove retaining pin at the back top of the firebox, just under the baffle. Lift baffle up and pull forward to disconnect from the supply tube. Tilt baffle sideways to drop down and remove from firebox.

Inspect gasket between baffle and supply tube. If necessary, replace with gasket # 139.5 available from your nearest Pacific Energy Dealer.

Re-install baffle assembly and insulation by reversing order.

Replacement Parts

(WHEN ORDERING, INCLUDE PART NUMBER WITH DESCRIPTION)

ITEM	DESCRIPTION	PART NO.	ITEM	DESCRIPTION	PART NO.
1.....	Surround (* Std-size).....	SPNE.SRND4	19.....	Air Shutter Assembly.....	WIND.4531
2.....	Front Panel, Left.....	SPNE.4599	20.....	Blower (RHS).....	SPNE.4576R
3.....	Bay Top.....	SPND.50374522-D	Blower (LHS).....	SPNE.4576L
4.....	Casing Top.....	SPND.4545	21.....	Blower Mounting Bracket.....	4541
5.....	Front Panel, Right.....	SPNE.4598	*22.....	Control Box Assembly.....	SPND.4583
6.....	Ash Lip Assembly.....	SPND.50374512			
7.....	Door Catch (c/w Bolt).....	WODC.1461.A			
8.....	Glass Clamp Set (4 pc.).....	SSER.1425			
9.....	Glass Bar Set (2 pc.).....	WODC.414001			
10.....	Replacement Glass (c/w Tape).....	DR31.WGLKIT			
.....	Door Gasket Kit (7/8").....	DR31.WDGKIT			
11.....	Door Casting, Arched Black.....	CAST.31ST			
.....	Door Casting, Radiant Black.....	CAST.31RSST			
.....	Door Casting, Arched Gold.....	CAST.31GD			
.....	Door Casting, Radiant Gold.....	CAST.31RSGD			
.....	Door Casting, Arched Nickel.....	CAST.31NI			
.....	Door Casting, Radiant Nickel.....	CAST.31RSNI			
12.....	Door Handle Assembly.....	WODC.4147C			
13.....	Flame Shield.....	WINS.4513			
14.....	Replacement Baffle Kit.....	SSER.DBAKIT			
15.....	Brick Rail, Set.....	SSER.RAILSET			
16.....	Firebrick Set.....	BRIC.SSERA			
17.....	Boost Manifold.....	4105			
18.....	O/A Cover.....	4557			

* Standard-Size Surround Assembly,
Embossed Panels..43 3/8" wide x 29 3/16" high

*NOT SHOWN

Fig. # 24

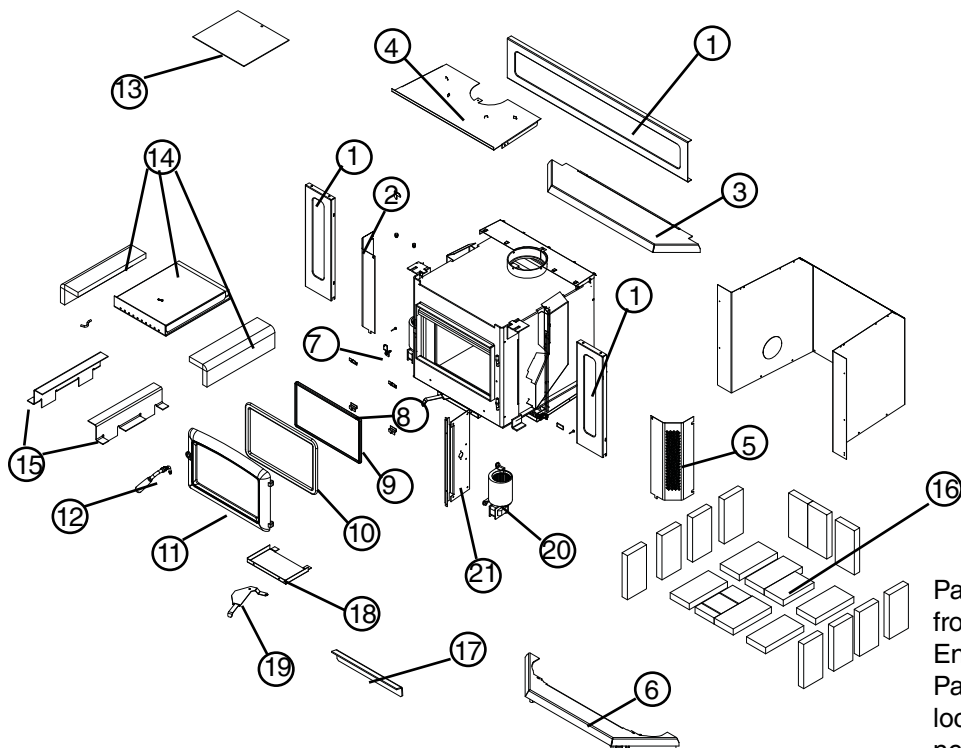

Parts may be ordered from your nearest Pacific Energy dealer. Contact Pacific Energy for the location of the dealer nearest you.

Appendix A

Understanding & Operating Your Pacific Energy Stove

The Pacific Energy line of woodstoves is a culmination of years of research and development. Designed to be efficient, clean-burning and user-friendly, this heater will give you years of warm service. However, a knowledgeable operator is still the most important factor for maximum performance and part of this is understanding the basic functions of this design.

Traditional wood stoves had a basic combustion system which allowed a considerable amount of heat energy to escape up the chimney as unburned gases and particulates (smoke). Pacific Energy has designed a system that solves the problem by burning the smoke and releasing the additional heat to the room.

This system has two critical design features:

1. Above fire secondary air injection:

The hollow "air baffle" injects super-heated secondary air just above the load. With the stove at the proper operating temperature, this will create a secondary flame that will be evident for approximately 1/3 of the total burn time.

2. High mass and thermal insulation:

The high mass (weight) acts as a heat storage and the thermal insulation keeps the combustion zone hot. Active flaming takes place during the first part of the burn. During this stage, heat is stored in the mass of the unit and is later released slowly and evenly. As wood chars, active flaming will diminish. This clean charcoal burning stage will last for a considerable length of time and refueling

should be avoided until the charcoal base has become quite small.

OPERATING TIPS

1. Always use dry, seasoned firewood, up to 18" long. Load wood endwise, a mixture of large and small pieces, on top of a good ash base (1" minimum).

2. Operate on a medium to high setting, for up to 1 hour from cold start. After the initial warm up period, refuel and leave the air control on a medium setting for 5 to 10 minutes more and then set the air control to the desired position.

3. If a slow burn is desired, set the air control to low. Active secondary burning should be present above the wood load. If it is not present or goes out shortly after, proper operating temperature has not been reached and the stove needs additional warm up time.

For additional operating, safety and maintenance information, refer to the installation manual.

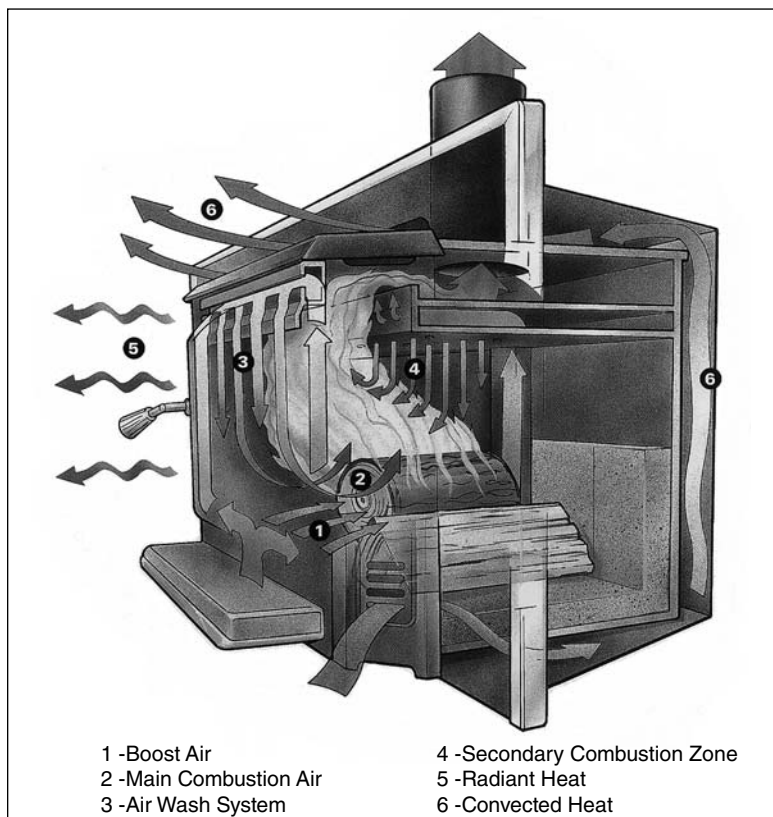

Troubleshooting

Problem	Cause	Cure
Excessive Creosote Buildup	1) Wood is too wet	- Use dry wood
	2) Turning down air control too soon	- Do not turn down until: a) there is a good bed of coals b) the wood is charred
	3) Draft too low	- Improper chimney height and/or diameter - Chimney plugged or restricted, check flue - Provide outside air for combustion
Glass is Dirty	1) See 1, 2, and 3 above	
	2) Door Gasket leakage	- Replace gasket - Check latch
Low Heat Output	1) Wood is wet	- Use dry wood
	2) Fire too small	- Build a larger fire
	3) Area too large	
	4) Poor insulation or open concrete	
Won't Burn Overnight	1) Air control set too high	- Set control lower
	2) Not enough wood	- Unsplit wood is preferred for overnight burns
	3) Possible air leak	- Door gasket needs changing
Stove Won't Burn	1) Combustion air supply is blocked	- Check outside air supply for obstructions (see Combustion Air section)
	2) Draft too low	- Chimney plugged or restricted Inspect and clean - Chimney oversized or otherwise unsuitable Consult Dealer



Firebrick Installation

Super Insert

This package contains 18 full-size firebricks, as well as 1 cut-size brick.

With the heater in the upright position, install firebricks as follows:

- Place firebricks on the bottom of the heater first. Total of 7 full-size and 1 cut brick.
- Next, install the side firebricks, 4 full-size each side.
- Lastly, install 3 full-size firebricks against the rear wall.

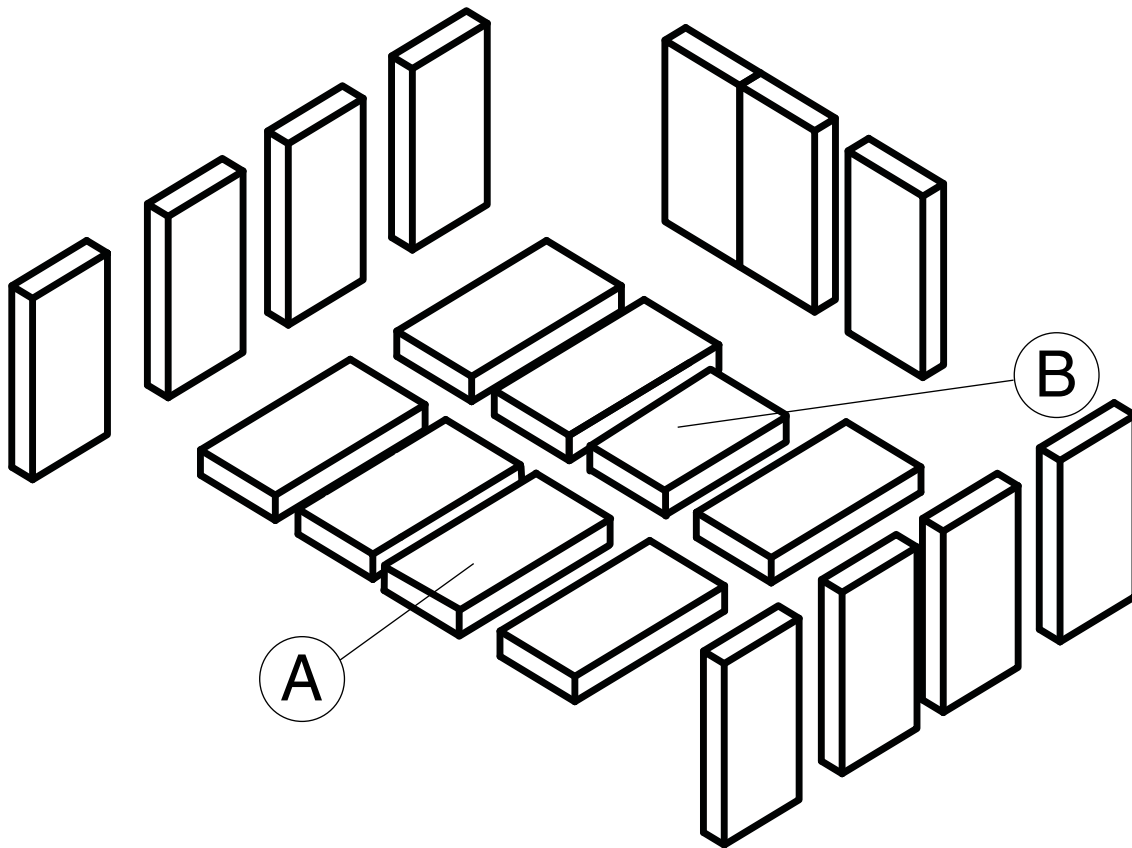

ITEM	SIZE	PART NUMBER
A	9" X 4 1/2" X 1 1/4" (230 mm x 115 mm x 32 mm)	<i>N. America</i> 5096.99
B	7 1/4" X 4 1/2" X 1 1/4" (184 mm x 115 mm x 32 mm)	245.0

NOTES:

NOTES:

Label



Intertek
WN#16407

Intertek
ETL# 4001507

**LISTED FACTORY BUILT FIREPLACE ACCESSORY INSERT
CERTIFIED FOR USE IN CANADA AND U.S.A.**

TESTED TO / ÉPROUVÉ SELON:
ULCS628-93 / UL1482(2011)

MODEL / MODÈLE: SUPER INSERT

501

SERIES / SÉRIE: E

INSTALL AND USE ONLY IN ACCORDANCE WITH PACIFIC ENERGY'S INSTALLATION AND OPERATING INSTRUCTIONS. CONTACT LOCAL BUILDING OR FIRE OFFICIALS ABOUT CODES, RESTRICTIONS AND INSTALLATION INSPECTION IN YOUR AREA. INSTALL AND USE ONLY IN MASONRY OR FACTORY BUILT FIREPLACE. DO NOT CONNECT THIS UNIT TO A CHIMNEY FLUE SERVING ANOTHER APPLIANCE.

COMPONENTS REQUIRED FOR INSTALLATION : FULL FLUE LINER CONFORMING TO CAN/ULC-S635 OR CAN/ULC-S640. IN U.S.A. FLUE LINER CONFORMING TO UL-1777 OR DIRECT FLUE CONNECTION ASSEMBLY.

OPTIONAL COMPONENTS: 3" VENT OFFSET(SPND.3OFFSETA), FAN, ELECTRICAL RATING 115V, 60HZ, 1.6 AMP. ROUTE POWER CORD AWAY FROM UNIT.

FOR USE WITH SOLID WOOD FUEL ONLY. DO NOT USE GRATE OR ELEVATE FIRE-BUILD WOOD FIRE DIRECTLY ON HEARTH. REPLACE GLASS ONLY WITH CERAMIC GLASS. INSPECT AND CLEAN CHIMNEY FREQUENTLY-UNDER CERTAIN CONDITIONS OF USE, CREOSOTE BUILDUP MAY OCCUR RAPIDLY. OPERATE ONLY WITH FEED DOOR CLOSED. OPEN TO FEED FIRE ONLY.

MINIMUM CLEARANCE TO COMBUSTIBLES (MEASURED FROM INSERT BODY)
DÉGAGEMENT MINIMUM AUX COMBUSTIBLES

A) ADJACENT SIDEWALL/ PAROI LATÉRALE ADJACENTE	254 MM / 10 IN
B) MANTEL	381 MM / 15IN
C) TOP FACING/ REVÊTEMENT SUPÉRIEUR	381 MM / 15IN
D) SIDE FACING/ REVÊTEMENT LATÉRAL	165 MM / 6.5 IN



INSTALL ONLY ON A NON-COMBUSTIBLE HEARTH. COMBUSTIBLE FLOOR BEYOND HEARTH MUST BE PROTECTED BY NON-COMBUSTIBLE FLOOR MATERIAL EXTENDING IN CANADA: 457 MM/ 18 IN ON THE FIRING SIDE (E) AND 200 MM / 8 IN TO THE OTHER SIDES (F)

IN U.S.A.: 406 MM / 16 IN TO THE FRONT OF (E) AND 200 MM / 8 IN TO THE SIDES OF THE FUEL LOADING DOOR (F)

AU CANADA: LE PLANCHER COMBUSTIBLE DEVANT LE FOYER DOIT ETRE PROTEGE PAR UN MATERIEL A L EPREUVE DU FEU QUI EXCEDE 457 MM / 18 PO DU CÔTÉ DU CHARGEMENT ET 203 MM / 8 PO SUR LES AUTRES CÔTÉS.

INSTALLEZ ET UTILISEZ SELON LES INTRUCTIONS D'INSTALLATION ET D'OPÉRATION DU PACIFIC ENERGY. BÂTIMENT OU POMPIERS LOCAUX DE CONTACT AU SUJET DES CODES, RESTRICTIONS ET D'INSPECTION D'INSTALLATION DANS VOTRE SECTEUR. INSTALLEZ ET EMPLOYEZ SEULEMENT EN MAÇONNERIE OU CHEMINÉE CONSTRUITE PAR USINE. NE RELIEZ PAS CETTE UNITÉ À UNE CONDUITE DE CHEMINÉE DE CHEMINÉE SERVANT UN AUTRE APPAREIL. MATERIEL REQUIS POUR L INSTALLATION:PLEIN REVÊTEMENT DE CONDUITE DE CHEMINÉE CONFORMÉMENT À CAN/ULC-S635 OR CAN/ULC-S640. COMPOSANTS FACULTATIFS: 3" VENT OFFSET(SPND.3OFFSETA), FAN, ÉLECTRIQUE 115V, 60HZ, 1.6 AMP. ITINÉRAIRE POWERCORD À PARTIR D'UNITÉ. POUR UTILISATION AVEC COMBUSTIBLE AU BOIS SEULEMENT. N'UTILISEZ PAS LA GRILLE OU N'ÉLEVEZ PAS LE FEU EN BOIS DE FIRE-BUILD DIRECTEMENT SUR LE FOYER. REMPLACES LA VITRE AVEC UNIQUEMENT DE LA VITRE CÉRAMIQUE. INSPECTEZ ET NETTOYEZ LA CHEMINÉE FRÉQUEMMENT-DANS CERTAINES CONDITIONS D'UTILISATION, L'HABILLAGE DE CRÉOSOTE PEUT SE PRODUIRE RAPIDEMENT. OPÉREZ SEULEMENT AVEC LA PORTE D'ALIMENTATION FERMÉE. OUVREZ-VOUS POUR ALIMENTER LE FEU SEULEMENT.



CAUTION

HOT WHILE IN OPERATION. DO NOT TOUCH. KEEP CHILDREN, CLOTHING AND FURNITURE AWAY. CONTACT MAY CAUSE SKIN BURNS. SEE NAMEPLATE AND INSTRUCTIONS.



MANUFACTURED BY:
PACIFIC ENERGY FIREPLACE PRODUCTS LTD.
2975 ALLENBY RD., DUNCAN, BC V9L 6V8

**U.S. ENVIRONMENTAL PROTECTION AGENCY
CERTIFIED TO COMPLY WITH JULY 1990
PARTICULATE EMISSION STANDARDS**

DATE OF MANUFACTURE

J	F	M	A	M	J	J	A	S	O	N	D
2009	2010	2011	2012	2013	2014						

MADE IN CANADA

190913 5050.74.B SPNE-1

The certification label is located on the left side casing of the insert.

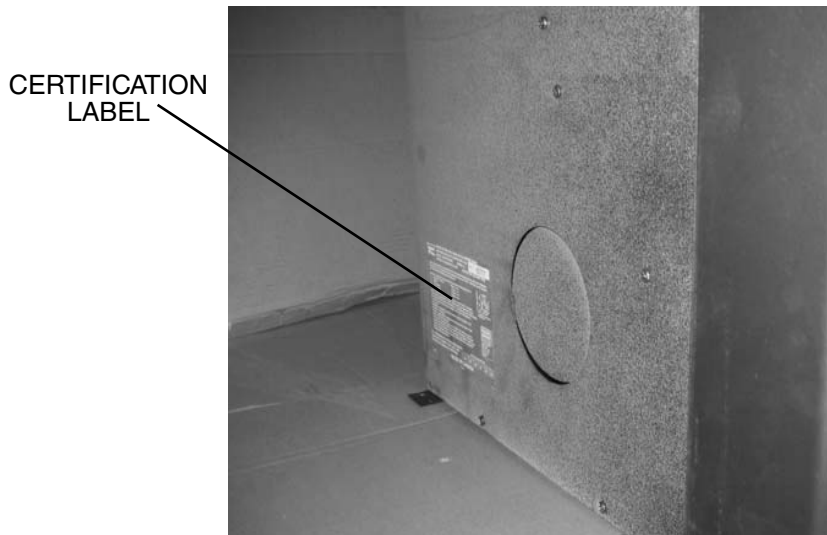



PACIFIC ENERGY FIREPLACE PRODUCTS LTD.
www.pacificenergy.net
Phone: 1-250-748-1184
2975 Allenby Rd., Duncan, B.C. V9L 6V8